

RACE TUNING INFORMATION

Subject

The following modifications increase and extend the power range, making the vehicle more competitive for the experienced racer.

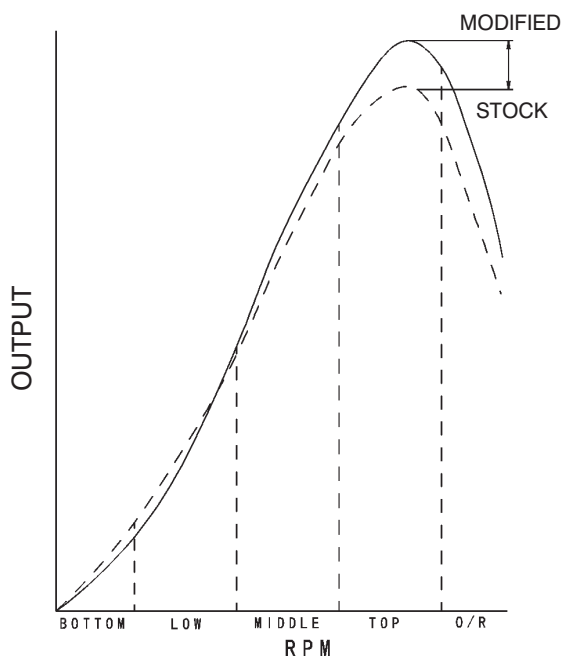

Modification Procedures

Cylinder:

The following modification increases midrange and high speed power while retaining low speed power.

- Shorten the cylinder height by removing 0.2 mm from the top surface (see illustrations).
- o The resulting surface finish must be as smooth as the original to insure that the head gasket will not leak.
- o The 0.2 mm cut off the cylinder top surface raises the compression ratio as shown in the table when the original 0.25 mm thick cylinder head gasket is installed.

Compression Ratio Model

Model	Stock	Modified
KX85-A3	9.2	9.8

Cylinder Ports:

- Measure the levels of the ports and grind the top of the ports to match the measurement in the figure (see illustration).
- Grind the shaded areas in the exhaust, intake and scavenging ports as shown in the illustrations.
- Polish the surfaces of the exhaust, scavenging, and intake passages, especially near the port into the cylinder, with emery cloth to allow smoother gas flow.

CAUTION

Kawasaki cannot accept any responsibility for the results of the modifications described in this bulletin.

Whenever the power output of an engine is increased, the reliability and durability of the engine decrease. This is especially true of competition engines, which are highly stressed even in stock form.

For best results, engine modifications should be made by an experienced engine tuner.

CAUTION

Maintain the original shape of the ports, and chamfer the sharp edges to prevent ring damage.

Removing more material than specified may result in a loss of power.

Intake and Exhaust Ports

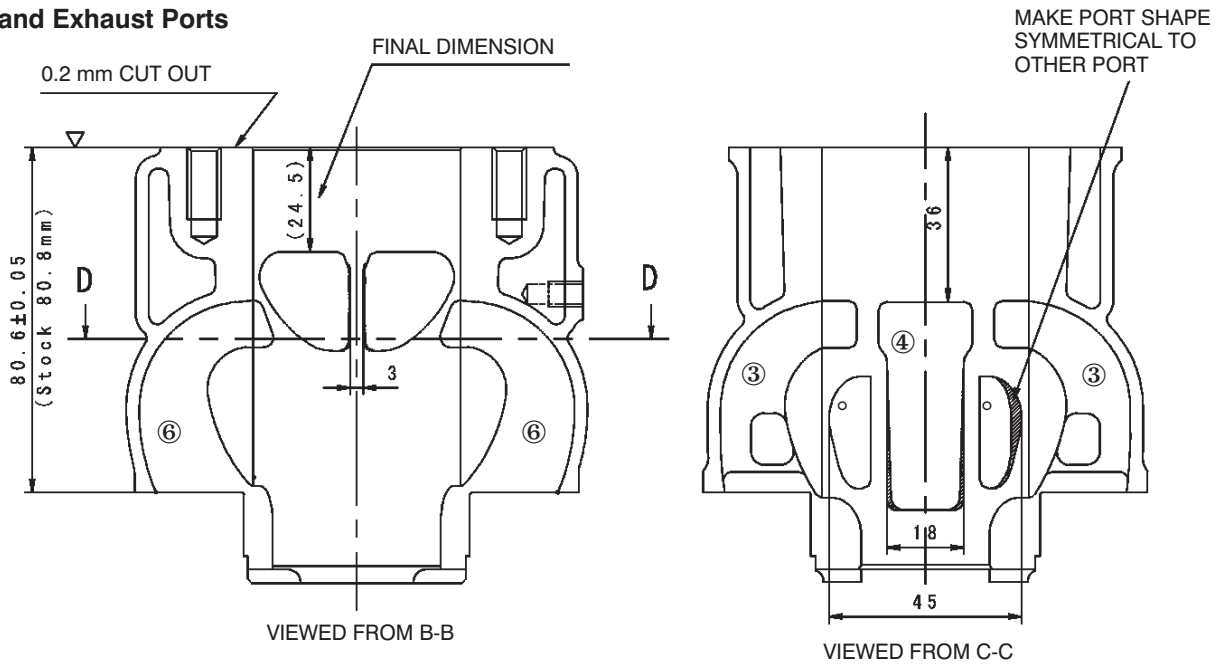

- 3. Sub-Scavenging Ports
- 4. Intake Port
- 5. Sub-intake Ports
- 6. Scavenging Passages

Cylinder Ports

All dimensions in mm

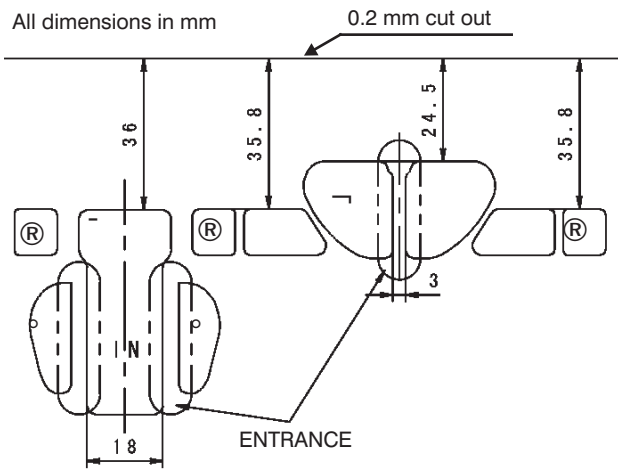

- 1. Exhaust Port
- 2. Scavenging Ports
- 3. Sub-Scavenging Ports
- 4. Intake Port
- 5. Sub-Intake Ports

Exhaust and Scavenging Ports

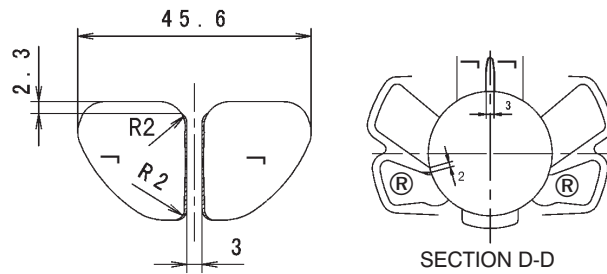

- 1. Exhaust Port
- 2. Scavenging Ports
- 3. Sub-Scavenging Ports

Intake and Exhaust Ports

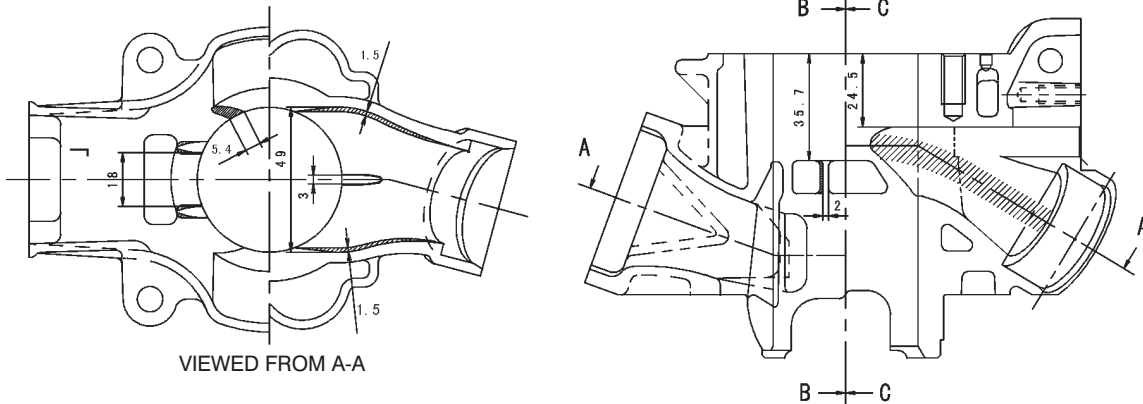

- 1. Intake Passage
- 2. Exhaust Passage

Ignition Timing:

- Modify the ignition timing by turning the stator 1 to 2 degrees clockwise (advance) or counterclock-wise (retard) as shown. Adjust according to race conditions.
- o There are three timing marks on the stator in 2 degree intervals; the stock machine uses the center of the marks. Shifting one mark changes the ignition timing by 2 degrees.

Stock	BTDC10°/12000 r/min (rpm)
Modified	BTDC8 to12°/12000 r/min (rpm)

Ignition Timing

TIMING MARK ON THE STATOR

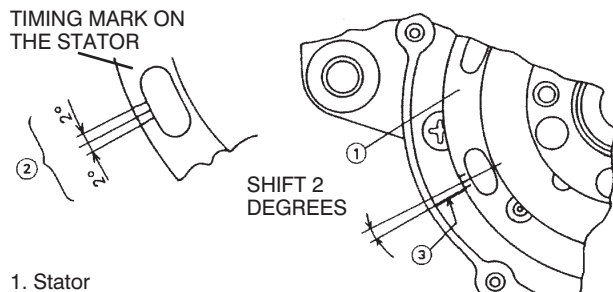

CAUTION

Use a racing fuel with Research Octane Number (RON) 105 or higher, to help prevent abnormal combustion caused by the increased compression pressure from this modification.

CAUTION

Use of leaded fuel is illegal in some countries, states or territories. Check local regulations before using leaded fuel.

Optional Carburetor Jets

The optional carburetor jets for the '02 KX85-A2 are listed on the last page of this bulletin.

Warranty Information

This bulletin is racing support information only, not warranty authorization.

Carburetor Setting and Optional Parts

'03 KX85-A3 and KX100-D3

1) Base Setting

Models	Carb Body Type	MJ	SJ	JN	CA	AS	NJ					BPP	BP	PO	ID Mark
							AB								
							1	2	3	4	5				
KX85-A2/B2	PWK28	#140	#45	NAPE-3	#3.5	1 ³ / ₈	φ0.6×2	φ0.6×2	-	φ0.6×2	φ0.6×2	4.5	φ0.8	φ0.4	G617A
KX100-D2	PWK28	#138	#45	NAPF-4	#3.5	1 ³ / ₈	φ0.6×2	φ0.6×2	-	φ0.6×2	φ0.6×2	4.5	φ0.8	φ0.4	G643A

2) JN Optional Parts

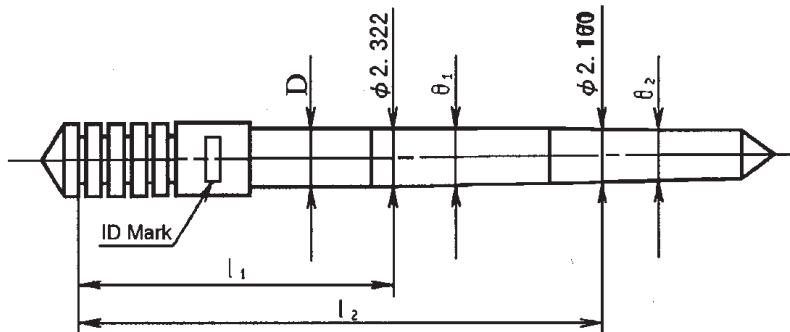

P/No.	ID Mark	D	l ₁	l ₂	θ ₁	θ ₂	A/F Condition
16187-1176	NAPC	φ 2.375	29.60	34.60	1°34'40"	3°45"	Richer
16187-1177	NAPD	φ 2.385	29.60	34.60	1°34'40"	3°45"	STD (Clip position 3rd)
* 16187-1178	NAPE	φ 2.395	29.60	34.60	1°34'40"	3°45"	
**16187-1179	NAPF	φ 2.405	29.60	34.60	1°34'40"	3°45"	STD (Clip position 4th)
16187-1180	NAPG	φ 2.415	29.60	34.60	1°34'40"	3°45"	Leaner
16187-1181	NAPH	φ 2.425	29.60	34.60	1°34'40"	3°45"	
16187-1182	NAQC	φ 2.375	30.05	35.05	1°34'40"	3°45"	Richer
16187-1183	NAQD	φ 2.385	30.05	35.05	1°34'40"	3°45"	Leaner
16187-1184	NAQE	φ 2.395	30.05	35.05	1°34'40"	3°45"	
16187-1185	NAQF	φ 2.405	30.05	35.05	1°34'40"	3°45"	Leaner
16187-1186	NAQG	φ 2.415	30.05	35.05	1°34'40"	3°45"	
16187-1187	NAQH	φ 2.425	30.05	35.05	1°34'40"	3°45"	Leaner

NAP is richer than NAQ (0.5 Clip Position).

3) MJ Optional Parts

P/No.	Number	Remark
92063-1337	#132	OP
-1338	#135	OP
** -1359	#138	STD
* -1360	#140	STD
-1361	#142	OP
-1362	#145	OP
-1363	#148	OP
-1364	#150	OP

NOTE

- * Applicable for KX085-A2/B2
- ** Applicable for KX100-D2

4) SJ Optional Parts

P/No.	Number	Remark
92064-1140	#40	OP
-1141	#42	OP
-1142	#45	STD
-1143	#48	OP
-1144	#50	OP

NOTE :

AB is the Air Bleed : the size of the hole in mm. The position is counted from the upper to the lower.

BPP is the Bypass Pitch : the distance in mm from the center of the main nozzle to the center of the Bypass hole.

BP is the Bypass : the size of the hole in mm.

PO is the Pilot Outlet : The size of the hole into the carburetor throat in mm.