

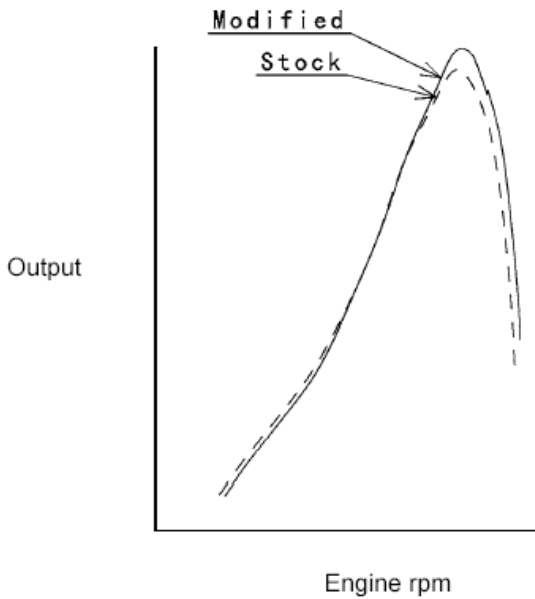

**RACE TUNING INFORMATION**

**Subject**

The following modifications increase midrange and high-speed power, making the vehicle more competitive for the experienced racer.



Whenever the power output of an engine is increased, the reliability and durability of the engine decrease. This is especially true of competition engines, which are highly stressed even in stock form.

For best results, engine modifications should be made by an experienced engine tuner.

**Modification Procedures**

**Exhaust Pipe**

Cut the pipe at the area shown to remove 5 mm from the length of the pipe to improve high-speed power and extend the power range.

Remove the fuel tank and the carburetor so that the pipe may be welded back together on the motorcycle for the best fit.

**⚠ WARNING**

**Do not weld with the fuel tank or the carburetor installed. Welding produces sparks and could cause a fire.**

**CAUTION**

**Kawasaki cannot accept any responsibility for the results of the modifications described in this bulletin.**

It may be necessary to reposition the muffler bracket.

Before final welding, fit the pipe on the motorcycle and tack weld the pipe joint.

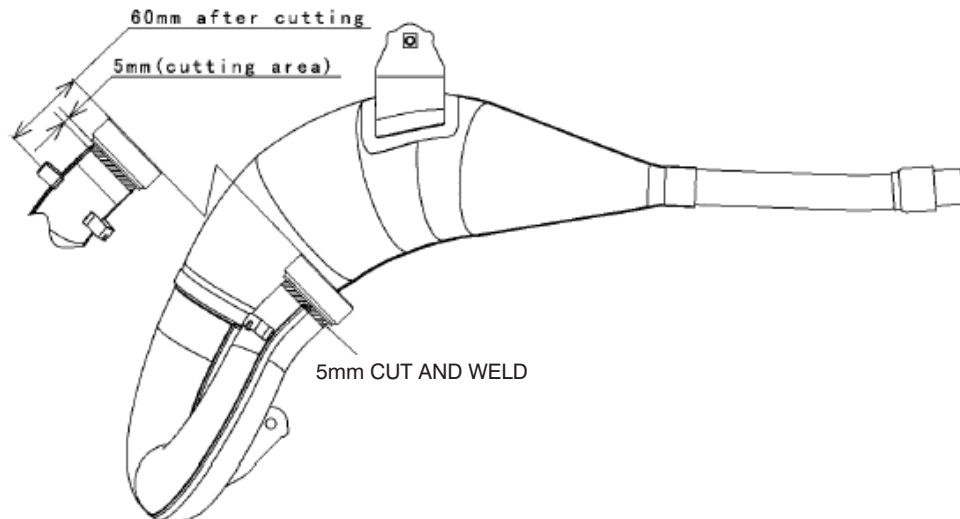

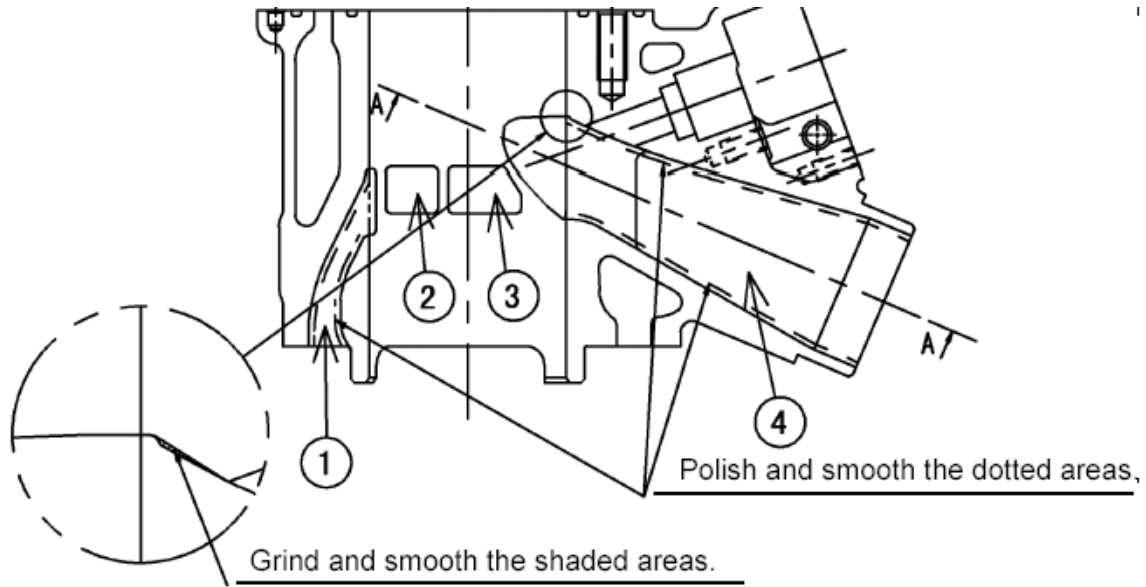

- 1. Number 3 Scavenging Passage
- 2. Sub-scavenging Port

- 3. Main Scavenging Port
- 4. Exhaust Passage

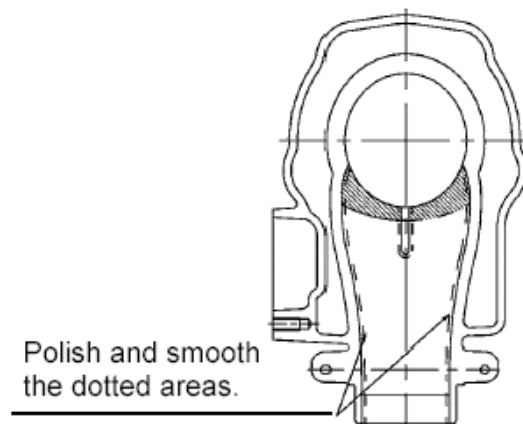
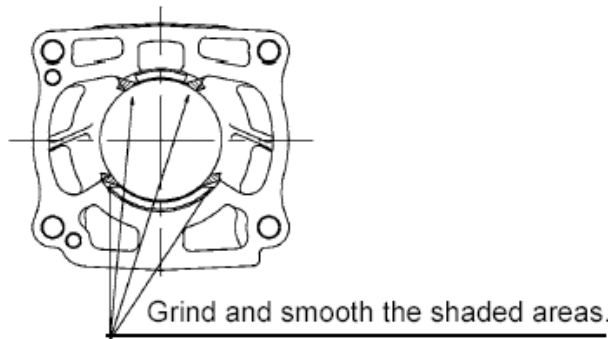

## Cylinder

The following modifications increase midrange and high-speed power while retaining low speed power.

Polish the surface of the exhaust and scavenging passages as shown.

Grind the tops of the exhaust and scavenging ports and also smooth stepped surfaces on the exhaust and scavenging passages as shown.

Smooth the corners at the scavenging rib areas as shown.

### CAUTION

Maintain the original shape of the ports, and chamfer the sharp edges to prevent ring damage.  
Removing more material than specified may result in a loss of power.

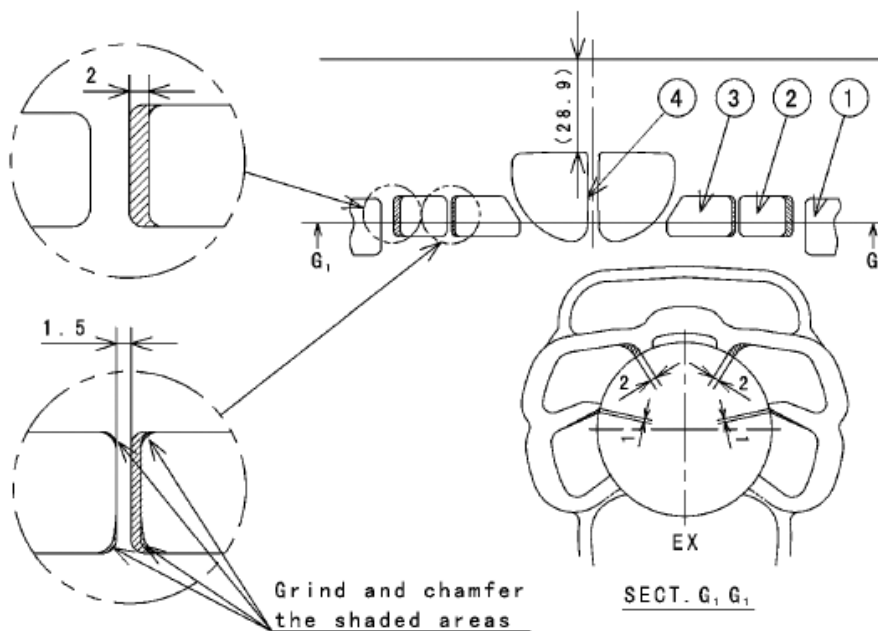
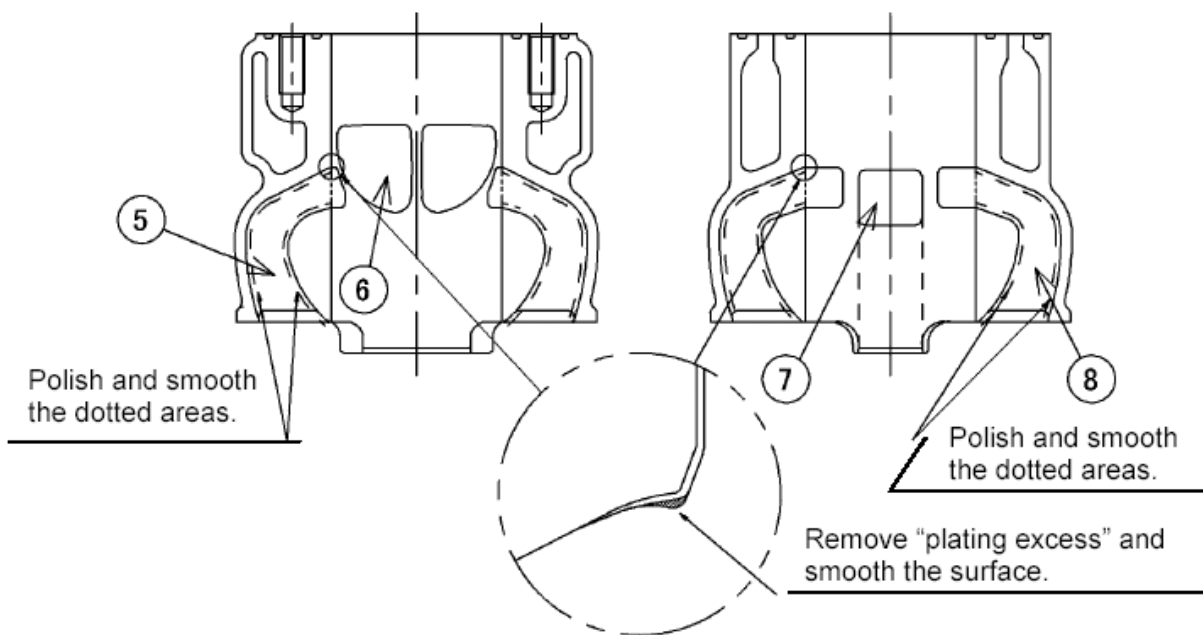

- |                                |                             |
|--------------------------------|-----------------------------|
| 1. Number 3 Scavenging Passage | 5. Main Scavenging Passage  |
| 2. Sub-scavenging Port         | 6. Exhaust Port             |
| 3. Sub-scavenging Port         | 7. Number 3 Scavenging Port |
| 4. Exhaust Passage             | 8. Sub-scavenging Passage   |

**Ignition Timing**

There are three timing marks on the stator in two-degree intervals (shifting one mark changes the timing two degrees). The stock machine uses the center mark.

Turn the stator 1~2 degrees clockwise (to advance) or counterclockwise (to retard) the ignition timing according to the rider's preference. Reset the timing as necessary based on rider preference.

**NOTE:**

- o Do not advance more than +2 degrees to help prevent abnormal combustion.

**NOTE:**

- o Use a fuel with Research Octane Number (RON) 98~100 or higher, to help prevent abnormal combustion.

<b>CAUTION</b>
<b>Use of leaded fuel is illegal in some countries, states or territories. Check local regulations before using leaded fuel.</b>

### Optional Carburetor Jets

No particular change in the carburetor setting should be required as a result of the engine tuning described on this service information. However, the setting may need to be adjusted according to the track conditions, temperature, atmospheric pressure, rider preference or other factors. The optional parts for the 2004 model KX125-M2 are shown in the last page of this service information.

#### NOTE:

- o Refer to the owner's manual for the correction factor information.

### Other Optional Parts

For the conditions described bellow, the following parts can be utilized effectively.

Condition	Optional Parts	
	Description	Part Number
(1) When the rear sprocket with 52-or-more teeth is installed.	Engine sprocket 12T	13144-1293
	Chain guide (for 12T)	13053-1465
(2) Heavy load conditions (sandy courses, climbing courses, endurance races and etc.)	Spark plug R7376-9	92070-1276
	Spark plug R7376-10	92070-1277

-----

### Warranty Information

-----

This bulletin is racing support information only, not warranty authorization.

## '04 KX125M Information of Carburetor setting & Optional Parts

### 1) Base Setting

Body	MJ	PJ	JN	CA	AS	NJ	BPP	BP	PO	Mark
TMX38 $\chi$	#420	#40	6CHJ11-82-3	5.75	2 1/2	S-9	2.5	$\phi$ 0.7	$\phi$ 0.7	J010 A

### 2) JN Optional Parts

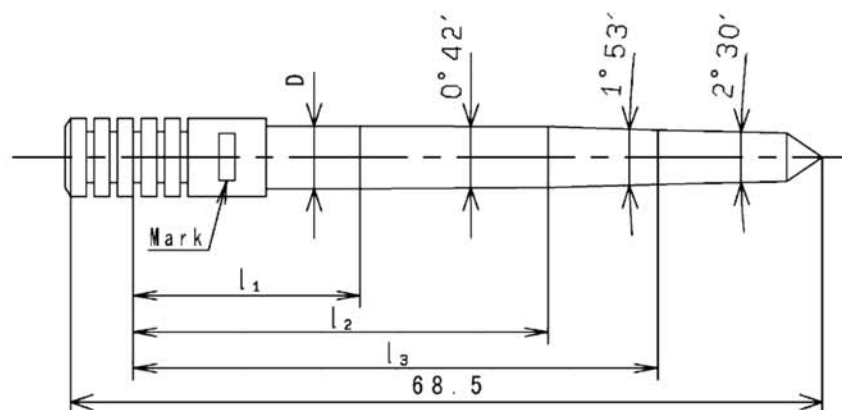

P/No.	MIKUNI No.	MARK	D	$l_1$	$l_2$	$l_3$	A/F Condition
16187-0006	J8-6CHJ11-80	6CHJ11-80	$\phi$ 2.80	9.82	33.00	43.961	STD (Clip position 3 rd)
16187-0007	J8-6CHJ11-81	6CHJ11-81	$\phi$ 2.81	10.09	33.00	43.961	
16187-0008	J8-6CHJ11-82	6CHJ11-82	$\phi$ 2.82	9.27	33.00	43.961	
16187-0009	J8-6CHJ11-83	6CHJ11-83	$\phi$ 2.83	9.02	33.00	43.961	
16187-0010	J8-6CHJ11-84	6CHJ11-84	$\phi$ 2.84	9.32	33.00	43.961	
16187-0001	J8-6CHJ10-80	6CHJ10-80	$\phi$ 2.80	11.41	33.50	44.461	lean
16187-0002	J8-6CHJ10-81	6CHJ10-81	$\phi$ 2.81	10.59	33.50	44.461	
16187-0003	J8-6CHJ10-82	6CHJ10-82	$\phi$ 2.82	9.77	33.50	44.461	
16187-0004	J8-6CHJ10-83	6CHJ10-83	$\phi$ 2.83	9.52	33.50	44.461	
16187-0005	J8-6CHJ10-84	6CHJ10-84	$\phi$ 2.84	9.52	33.50	44.461	

\*6CHJ11 is richer than 6CHJ10 (0.5 clip position)

### 3) CA Optional Parts

KHI No.	MIKUNI No.	MARK	Remark
16025-0002	832-42020-5.5	# 5.5	OP
16025-0003	832-42020-5.75	# 5.75	STD
	5		
16025-0004	832-42020-6.0	# 6.0	OP

### 5) MJ Optional Parts

KHI No.	MIKUNI No.	MARK	Remark
92063-035	4/042-400	# 400	OP
92063-1472	4/042-410	# 410	OP
92063-1473	4/042-420	# 420	STD
92063-1474	4/042-430	# 430	OP
92063-1475	4/042-440	# 440	OP
92063-0001	4/042-470	# 470	OP

### 4) PJ Optional Parts

KHI No.	MIKUNI No.	MARK	Remark
92064-1214	N224103-35	# 35	OP
92064-1215	N224103-37.5	# 37.5	OP
92064-1216	N224103-40	# 40	STD
92064-1217	N224103-42.5	# 42.5	OP
92064-1218	N224103-45	# 45	OP